

Drivetrain

GAS ENGINES























Best-in-class solutions for
efficient power generation

an **Engenco** company

Gas engines from 209 to 2,065 kWb

50 Hz or 60 Hz

| | | | |
|-----------|---|-------|----------|
| SGE-100EM |  | 2,065 | 2,065 kW |
| SGE-86EM |  | 2,065 | 2,065 kW |
| SGE-56HM |  | 1,040 | 1,350 kW |
| SGE-42HM |  | 1,040 | 1,040 kW |
| SGE-24HM |  | 520 | 520 kW |
| SGE-56SR |  | 660 | 870 kW |
| SGE-48SR |  | 510 | 840 kW |
| SGE-36SR |  | 440 | 660 kW |
| SGE-24SR |  | 255 | 420 kW |
| SGE-18SR |  | 220 | 330 kW |
| SGE-56SM |  | 1,030 | 1,100 kW |
| SGE-48SM |  | 725 | 906 kW |
| SGE-36SM |  | 550 | 700 kW |
| SGE-24SM |  | 360 | 453 kW |
| SGE-18SM |  | 275 | 350 kW |
| SGE-56SL |  | 560 | 1,150 kW |
| SGE-48SL |  | 561 | 1,060 kW |
| SGE-36SL |  | 418 | 790 kW |
| SGE-24SL |  | 281 | 530 kW |
| SGE-18SL |  | 209 | 350 kW |

The Guascor Energy gas engine range has been designed and tailored to help meet our customers' challenges in a dynamic market environment.

Our models range from 190 to 2,065 kW, fulfilling the requirements of wide spectrum of applications in terms of efficiency, reliability, flexibility, and environmental compatibility.

The products offer low lifecycle costs and an excellent return of investment.

- Data referred to thermal balances published at 20th November 2020

- Mechanical power of the SL Series includes Standby and Prime app



Table of contents

best-in-class, high-efficiency, low-emission gas engines and gensets are designed for various applications such as power generation, cogeneration, and waste to energy. These engines are suitable for a broad range of commercial, industrial and municipal uses with long service intervals, easy maintenance and low fuel consumption.

| | |
|-----------|---|
| 01 | S Series gas engines Page 07 |
| 02 | H Series gas engines Page 21 |
| 03 | E Series gas engines Page 27 |
| 04 | Containers Page 32 |
| 05 | Performance data overview Page 34 |



We power the world with innovative gas engines

SL- Gas engines:

A robust, reliable and fuel flexible power generation

- Mechanical power output: from 209 kWb to 1,150 kWb (1,200, 1,500 and 1,800 rpm)
- Powered by natural gas, landfill and sewage gas, flare and well gas, syngas
- Proven reliable and robust design
- Fast start availability
- Fuel flexibility
- Fuel blending availability
- Eco friendly
- Cost efficient implementation and service
- Load acceptance great flexibility
- Best in class global efficiency

SL gas engines

- SGE-18SL
- SGE-24SL
- SGE-36SL
- SGE-48SL
- SGE-56SL





We power the world with innovative gas engines

SGE-SL

Gas engines

The SL gas engines offer systems for a large variety of applications as Cogeneration/trigeneration, Sewage/landfills/biodigestion processes for utilities and public buildings, and different kind of industries: textile, cement, food processing,... as well as greenhouses.

Also is able to operate with a low quality gases, flare gas and syngas from a gasification process.

containerized CHP biogas genset solution for Johannesburg Water, South Africa.



Applications

- Power generation (cont, LTP, ESP, PRP,...)
- CHP and Trigeneration
- Waste to power
- Marine applications
- Mechanical drive (for pump driving)

References

- Universities
- Wesleyan (USA)
- Wolverhampton (UK)
- Utilities (Landfill, sewage plants)
- ETE (Brazil)
- Johannesburg (South Africa)
- Fypasa (Mexico)
- Storms Hog (USA)

We power the world with innovative gas engines

- Fuel blending system available for biogas gensets
- Integrated proprietary GCS-E engine and GCS-G genset control systems
- High flexibility through modularity

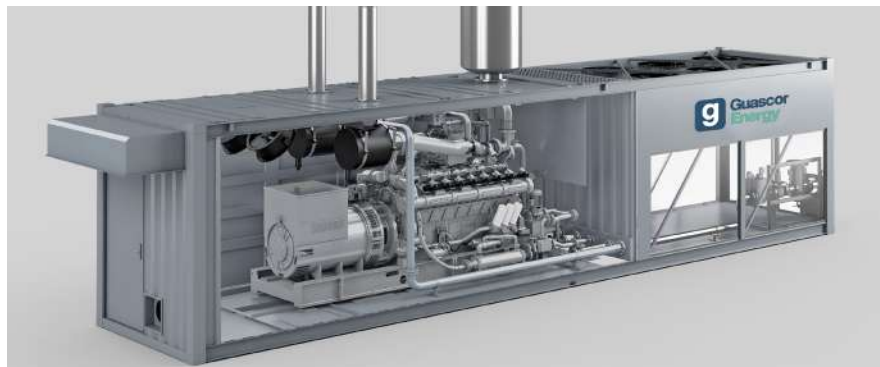

SGE-56 SL containerized genset for Cogeneration



SGE-48SL Gas Genset.

Power generation - CHP

| | |
|----------------------------|--|
| Power output | 241 to 1058 kWe (natural gas) |
| Fuel | Natural gas, biogas, landfill gas, sewage gas, flare gas, well gas, syngas |
| Frequency | 50 and 60 Hz |
| Speed | 1,200 / 1,500 / 1,800 rpm |
| Electric efficiency | 36 - 39,8 % |
| Thermal efficiency | 51 - 55 % |
| Total efficiency | 90 - 91.5 % |
| NOx emissions | 500 mg / Nm3 |

(*) Lower emission engines are available.

Best-in-class global efficiencies for CHP in Natural gas S Series: 500 1,030 kWe

Physical dimensions

| | |
|------------------------------------|--------------------|
| Approximate weight (genset) | 4,000 to 10,000 kg |
| Length | 2.8 - 4.3 m |
| Frequency | 1.5 - 1.7 m |
| Height | 2.1 - 2.3 m |

- Lean burn, turbocharged and aftercooled
 - Electronically carburated
 - Fuel blending capability (natural gas/biogas) available
 - Single or double circuit cooling system
 - High cooling temperature option in main circuit 120°C
 - Different auxiliary cooling circuit temperatures
 - Oil cooler in main circuit option available
 - Dry/wet exhaust manifold
 - Single/double stage intercooler
 - Reduced oil consumption
 - Emissions control
 - Compliant with the U.S. emissions standards
 - Fast start availability
- Supplied as a stand-alone engine, genset or in a fully containerized unit

We power the world with innovative gas engines

SGE-SL

Marine gas engines

The complete family of SGE-SL gen-sets with a variety of applications such as Auxiliary power generation and electrical propulsion - constant speed.

Applications

For a large variety of vessels: tugboats, tankers, ferries, oceanographic, special vessels and others

- Auxiliary power generation
- Electrical propulsion



A gas fueled vessel.

We power the world with innovative gas engines

- Working speeds: 1,500 & 1,800 rpm
- Emissions compliant IMO TIER III.



SGE-56 SL marine gas engine.



Containerized 56SL genset for harbour use.

Power generation

| | |
|----------------------|------------------------------|
| Power output* | 320 - 1110 KVA (256-888 kWe) |
| Fuel | LNG. Methane number from 70 |
| Frequency | 50 and 60 Hz |
| Speed | 1,500 / 1,800 rpm |

Physical dimensions

| | |
|------------------------------------|------------------------------|
| Approximate weight (genset) | 320 - 1110 KVA (256-888 kWe) |
| Length | LNG. Methane number from 70 |
| Width | 50 and 60 Hz |
| Height | 1,500 / 1,800 rpm |

- Working speeds: 1,500 and 1,800 rpm
- Fuel: LNG (Liquefied Natural Gas). Methane number from 70
- Cooling configurations: With mechanical and electrical water pumps
- Water circuits T°: 90/40 °C

(*) Based on existing gas engines power ratings for the ambient conditions required in the marine market.

Note 1) For a large variety of vessels as tugboats, tankers, ferries, oceanographic, special vessels.

We power the world with innovative gas engines

SR- Gas engines:

Designed for rich burn power generation

- Mechanical power output: from 220 kW to 870 kWb (1,800 rpm) • Powered by natural gas
- Robust design
- Eco friendly
- Load acceptance great flexibility

SR gas engines

- SGE-18SR
- SGE-24SR
- SGE-36SR
- SGE-48SR
- SGE-56SR





We power the world with innovative gas engines

SGE-SR

SR Engines

This engine is spark ignited and powered by natural gas and well gas. Robust and reliable, has great flexibility for load acceptance and great performance for power generation and cogeneration.

Applications

- Power Generation
- Cogeneration



LNGo micro-scale natural gas liquefaction system.

We power the world with innovative gas engines

- Only suitable for 60 Hz markets (USA)
- Part of the LNGo solution package



LNGo Power modules (SL), Altagas Ltd. British Columbia, Canada.

| Power generation - CHP | |
|------------------------|----------------------------|
| Power output* | 273 to 844 kW _e |
| Fuel | Natural gas, Well gas |
| Frequency | 60 Hz |
| Speed | 1,800 rpm |
| Electric efficiency | 33 - 34 % |

| Physical dimensions | |
|-----------------------------|--------------------|
| Approximate weight (genset) | 4,000 to 10,000 kg |
| Length | 2.8 - 4.3 m |
| Width | 1.5 - 1.7 m |
| Height | 2.1 - 2.3 m |

- Rich burn
- Turbocharged and aftercooled
- Wet Exhaust Manifold
- Electronically carbureted
- Powered by natural gas and well gas
- Double circuit cooling system
- Different auxiliary cooling circuit temperatures
- Single/double stage intercooler
- Great flexibility for load acceptance
- Emissions control
- Compliant with the U.S. emissions standards

SM- Gas engines:

Designed for fuel flexible power generation

- Mechanical power output: from 1,055 to 1,100 kWb when powered by natural gas, landfill, and sewage gas (1,500 and 1,800 rpm)
- Mechanical power output from 275 to 1067 kWb when powered by propane LPG (1,500 and 1,800 rpm)
- Powered by natural gas, landfill, sewage gas and propane
- High efficiency
- Load acceptance great flexibility
- High quick start and operational availability
- Standard interchangeable parts

SM gas engines

- SGE-18SM
- SGE-24SM
- SGE-36SM
- SGE-48SM
- SGE-56SM





We power the world with innovative gas engines

SGE-SM

Gas engines

The SM gas engine offers systems for a large variety of applications such as Cogeneration/trigeneration.

The SM gas engine is also able to operate with other types of gases like propane or biogases.

| Applications | References | | | | |
|---|--|----------|----------|--|---|
| <ul style="list-style-type: none">• Power generation• CHP and Trigeneration• Waste to power | <table><thead><tr><th>SGE-24SM</th><th>SGE-56SM</th></tr></thead><tbody><tr><td><ul style="list-style-type: none">• Puerto Rico (propane), Food industry• Trigeneration</td><td><ul style="list-style-type: none">• Anaerobic digestion from POME and animal manure in Thailand and Indonesia</td></tr></tbody></table> | SGE-24SM | SGE-56SM | <ul style="list-style-type: none">• Puerto Rico (propane), Food industry• Trigeneration | <ul style="list-style-type: none">• Anaerobic digestion from POME and animal manure in Thailand and Indonesia |
| SGE-24SM | SGE-56SM | | | | |
| <ul style="list-style-type: none">• Puerto Rico (propane), Food industry• Trigeneration | <ul style="list-style-type: none">• Anaerobic digestion from POME and animal manure in Thailand and Indonesia | | | | |



Olefin food industry plant, two containerized SGE-24SM engines.

- Great flexibility for running with fuels as propane
- Integrated proprietary GCS-E engine and GCS-G genset control systems
- High flexibility through modularity



48SM Engine.



A CHP package of SM genset.

- Lean burn, turbocharged and aftercooled
- Miller cycle
- Electronically carburated
- Double circuit cooling system
- Different auxiliary cooling circuit temperatures
- Oil cooler in main circuit option available
- Dry/Wet exhaust manifold
- Single/double stage intercooler
- Reduced oil consumption
- Emissions control
- Compliant with the U.S. emissions standards

Power generation - CHP

| | |
|----------------------------|------------------------------------|
| Power output* | 275 to 1030 kWe (Propane (LPG)) |
| Fuel | Propane |
| Frequency | 50 and 60 Hz |
| Speed | 1,500 / 1,800 rpm |
| Electric efficiency | 36 - 36.3 % |
| Thermal efficiency | 53 - 55 % |
| Total efficiency | 91 - 93 % |
| NOx emissions | 500 mg / Nm3 |

Power generation

| | |
|----------------------------|---------------------|
| Power output* | 1,025 to 1,060 kWe |
| Fuel | Natural gas, biogas |
| Frequency | 50 and 60 Hz |
| Speed | 1,500 / 1,800 rpm |
| Electric efficiency | 39 - 41 % |
| Thermal efficiency | 51 - 52 % |
| Total efficiency | 92 % |
| NOx emissions | 500 mg / Nm3 |

Physical dimensions

| | |
|------------------------------------|--------------------|
| Approximate weight (genset) | 4,000 to 10,000 kg |
| Length | 2.8 - 4.3 m |
| Width | 1.5 - 1.7 m |
| Height | 2.1 - 2.3 m |

Supplied as a stand-alone engine, genset or in a fully containerized unit

We power the world with innovative gas engines

HM- Gas engines:

Designed for high performance power generation

- Mechanical power output: from 520 to 1,350 kWb (1,200, 1,500 and 1,800 rpm)
- Powered by natural gas, sewage gas and landfill gas
- Fuel flexibility and fuel blending availability
- High performance
- Low life cycle cost
- Cost efficient
- Compact solution
- Best-in-class electrical efficiencies in biogas and natural gas

HM gas engines

- SGE-24HM
- SGE-42HM
- SGE-56HM





We power the world with innovative gas engines

SGE-HM

Gas engines

The proven HM engine series offers a robust design with Miller cycle.

This is the first reference of the 42HM model engine recently released.

A cost efficient compact solution for power generation and cogeneration processes.

Applications

- Power generation (50 Hz and 60 Hz)
- CHP - cogeneration

References

- Sokołowie Podlaskim - Poland
- Supply two genset SGE-42HM
 - Power output - 2 MWe
- Customer; SOKOŁÓW SA



Condensation plant - Sokołowie Podlaskim - Poland.

We power the world with innovative gas engines

- Proven design
- High thermal efficiency
- Integrated proprietary GCS-E engine and GCS-G genset control systems



SGE-42HM genset.

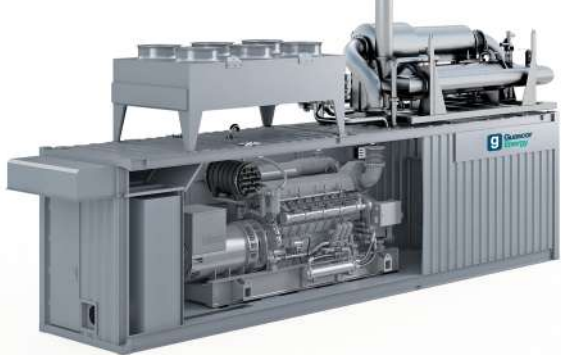

SGE-56HM containerized genset.

| Power generation - CHP | |
|------------------------|---------------------------|
| Power output* | 502 to 1,315 kWe |
| Fuel | Natural gas, biogas |
| Frequency | 50 and 60 Hz |
| Speed | 1,200 / 1,500 / 1,800 rpm |
| Electric efficiency | 41 - 43 % |
| Thermal efficiency | 47 - 49 % |
| Total efficiency | 89 - 91 % |
| NOx emissions | 500 mg / Nm ³ |

Best-in-class electrical efficiencies in Biogas (W2P) engines, H Series: 24HM: 500 kWe; 42HM: 1,000 kWe; 56HM: 1,300 kWe

Best-in-class electrical efficiencies in Natural gas H Series: 24HM: 500 kWe; 56HM: 1,300 kWe

| Physical dimensions | |
|---------------------|--------------------|
| Approximate weight | 6,200 to 11,000 kg |
| Length | 4.0 - 5.6 m |
| Width | 1.8 - 1.9 m |
| Height | 1.7 - 2.3 m |

- Miller cycle
- High efficiency
- Turbocharged and aftercooled
- Dry exhaust manifold
- Electronically carbureted
- Fuel blending capability natural gas/biogas available
- Oil cooler in main circuit option available
- Single/double stage intercooler
- Reduced oil consumption
- Emissions control

Supplied as a stand-alone engine, genset or in a fully containerized unit

HM: Key features

CONTROL SYSTEM

- Proprietary, fully integrated, engine control system for optimized performance and diagnosis

LUBRICATION SYSTEM

- O/C in HT or LT circuit
Internal oil pump
- Centrifugal oil filter for W2P applications

POWER TRAIN

- High swirl pistons optimized for high efficiency
- Rings designed for optimized oil consumption

INTAKE & EXHAUST SYSTEMS

- One high-efficiency turbocharger, water cooled
- Two-stage, on engine integrated, charge cooler
- Two intake manifolds outside the engine. Dry exhaust manifolds, inside the engine

COMBUSTION SYSTEM

- Two camshafts, Miller cycle
- Cylinder head designed for maximum volumetric efficiency with water-cooled exhaust valve seats
- Pre-chamber sparkplugs

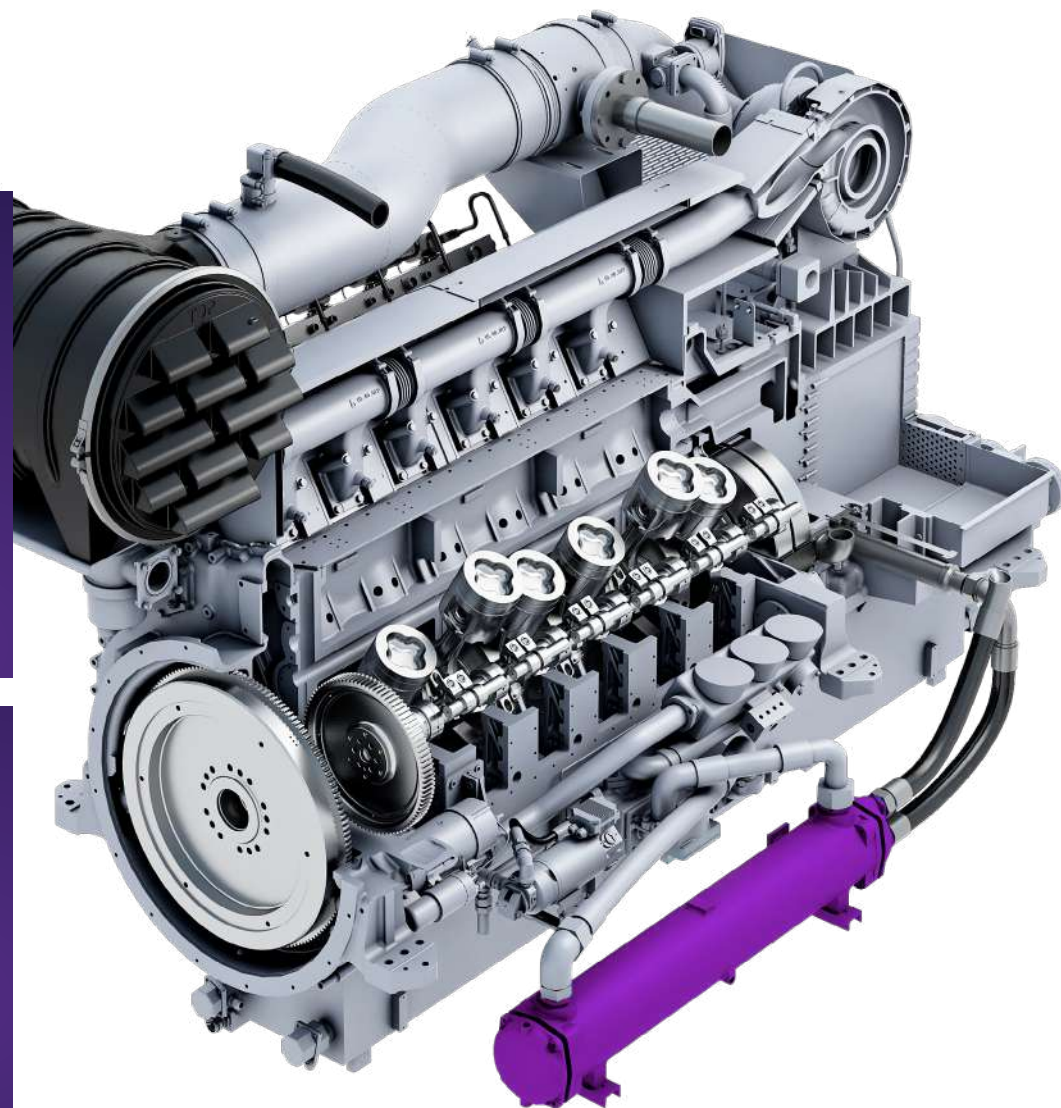

We power the world with innovative gas engines

EM- Gas engines:

Designed for Best-in-class power generation

- Mechanical power output: 2,065 kWb (1,200 and 1,500 rpm)
- Direct Drive in 60 Hz (1,200 rpm) option
- Powered by natural gas
- Best-in-class, excellent efficiency in small footprint
- Lowest emissions
- High operational availability
- Low life cycle cost

EM gas engines

- SGE-86EM
- SGE-100EM





We power the world with innovative gas engines

SGE-EM

Gas engines

The EM gas engines are the most compact competitive choice with the ability to deliver high power output with even 200 mg/Nm³ NO_x emissions level.



Applications

- Power generation (50 Hz and 60 Hz)
- CHP - cogeneration

We power the world with innovative gas engines

- Highest efficiency in its class
- Lower emissions
- Lower footprint
- Best power/performance ratio
- Direct Drive for 60 Hz (1,200 rpm) option
- Lower OPEX

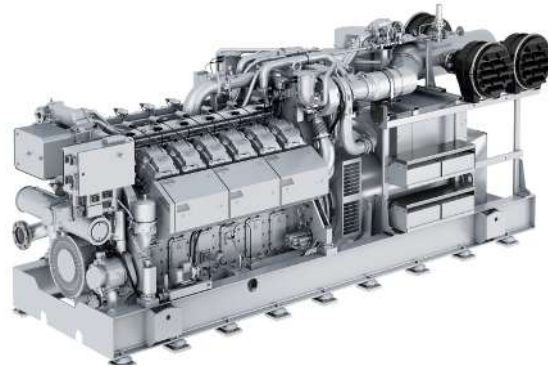

SGE-86EM genset.



Internal section of the SGE-86EM engine.

| Power generation - CHP | |
|------------------------|------------------|
| Power output* | 2,012 kWe |
| Fuel | Natural gas |
| Frequency | 50 and 60 Hz |
| Speed | 1,200 /1,500 rpm |
| Electric efficiency | 45.4 % |
| Thermal efficiency | 41 % |
| Total efficiency | 86.4 % |
| NOx emissions | 500 mg / Nm3 NOx |

Best-in-class electrical efficiency in Natural gas E Series: 86 EM: - 2,000 kWe

| Physical dimensions | |
|---------------------|-----------|
| Approximate weight | 14,515 kg |
| Length | 6.4 m |
| Width | 2.0 m |
| Height | 2.3 m |

- Miller cycle
- High efficiency turbocharger
- Dry exhaust manifold
- Electronically carburated
- New piston design for best performance
- Two circuit cooling systems
- Auxiliary cooling circuit variable temperature new concept.
- Oil cooler in main circuit
- Direct Drive for 60 Hz (1,200 rpm) option
- 90,000 hours for major overhaul
- Double stage intercooler
- Reduced oil consumption
- Emissions control

Supplied as a stand-alone engine, genset or in a fully containerized unit

Note 1) Also available at 200 mg/Nm3 NOx.

EM: Key features

LUBRICATION SYSTEM

- On engine integrated O/C (HT water circuit)
- External, accessible, oil pump
- Centrifugal oil filter

CONTROL SYSTEM

- Proprietary, fully integrated, engine control system for optimized performance and diagnosis

COMBUSTION SYSTEM

- One single camshaft, Miller cycle
- Cylinder head designed for maximum volumetric efficiency with water-cooled exhaust valve seats
- Pre-combustion chamber with direct gas injection optimized for high efficiency and low emissions

INTAKE & EXHAUST SYSTEMS

- Two high-efficiency turbocharger, water cooled, with two bypass valves
- Two-stage, on engine integrated, charge cooler
- One intake manifold inside the engine
- Dry exhaust manifolds, outside the engine

POWER TRAIN

- Forged steel piston for high peak combustion pressures
- Rings designed for optimized consumption
- Low mass and high resistance connecting rod

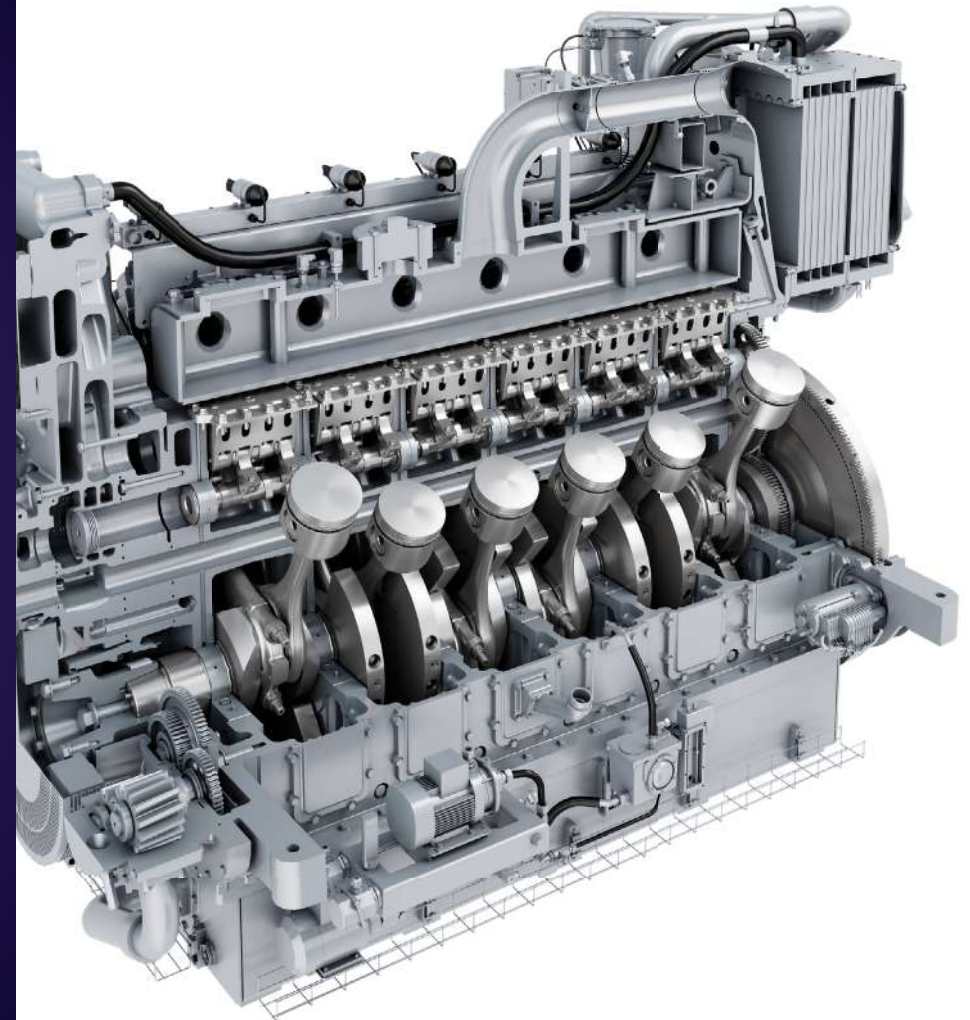



CE 2015
N° 104454 P10.GRU.15
GH
www.ghisa.com

500 kg

Container models

| Container type | 40 feet container with embedded aircooler | 40 feet container with top mounted aircooler | 30 feet container with remote radiator | Soundproof canopy |
|--------------------------------------|--|--|---|--|
| Brief description | <p>The container is comprised of following individual areas:</p> <p>Engine room is the base module containing the genset, cooling pumps, thermostatic valves and daily oil tank.</p> <p>Cabinet room containing the electrical, control and power panels.</p> <p>Aircooler room containing the cooling system and gas ramp. When necessary also will include the heat recovery skid.</p> <p>Top mounted area- containing the exhaust silencer, chimney and if necessary the exhaust heat recovery. (for local assembly) (*) External use</p> | <p>The container is comprised of following individual areas:</p> <p>Engine room is the base module containing the genset, cooling pumps, thermostatic valves and daily oil tank. Also a heat water recovery skid can be included if necessary.</p> <p>Cabinet room containing the electrical, control and power panels.</p> <p>Top mounted area containing the exhaust silencer, chimney and the genset cooling system. If necessary also will include the exhaust heat recovery skid. (for local assembly) (*) External use</p> | <p>The container is comprised of following individual areas:</p> <p>Engine room is the base module containing the genset, cooling pumps, thermostatic valves and daily oil tank.</p> <p>Cabinet room containing control and power panels.</p> <p>The gas ramp will be installed on foot of it in one side.</p> <p>The cooling system, aircooler and exhaust silencer will be installed outside the container. Indoor use.</p> | <p>The container is comprised of a common bedframe that includes:</p> <p>The genset, pumps, thermostatic valves, plate heat exchanger, expansion vessels, exhaust recovery system, oil tank and control and power panels.</p> <p>The exhaust silencer will be installed on the roof and the aircooler outside in a remote area. (*) External use</p> |
| Sound pressure level | Down to 75 dB (A) in 10m except for the 56SL T30 model with 75 dB (A) in 1 m | Down to 75 dB (A) in 10m except for the 56SL T30 model with 75 dB (A) in 1 m | Down to 75 dB (A) in 1 m | Down to 75 dB (A) in 1 m |
| Ambient temperatures (*) | The container is designed for ambient temperatures of -18°C to 35°C with an option to reach up to 45°C | The container is designed for ambient temperatures of -18°C to 45°C | The container is designed for ambient temperatures of -10°C to 29.5°C | The container is designed for ambient temperatures of 0°C to 35°C |
| Dimensions | Length:12,192 mm; Width: 2,438 mm; Height: 2,896 mm | Length:12,192 mm; Width: 2,438 mm; Height: 2,896 mm | Length:9,144 mm; Width: 2,438 mm; Height: 2,896 mm | Length:6,000 mm; Width: 2,000 mm; Height: 3,100 mm |
| Applications by engine models | <p>Power generation: S Series including 56SLT30. H Series Line engine.</p> <p>Cogeneration: All engines except for V engines of the H Series and 56 lite engines (SL, SM)</p> | <p>Power generation: H Series except for 24 HM, SM gas propane.</p> <p>Cogeneration: H Series except for 24HM, SM gas propane and 56 liter engines</p> | Fast start: 56SL T30 engine | Power Generation, Cogeneration for all L engines |

Container: Key features

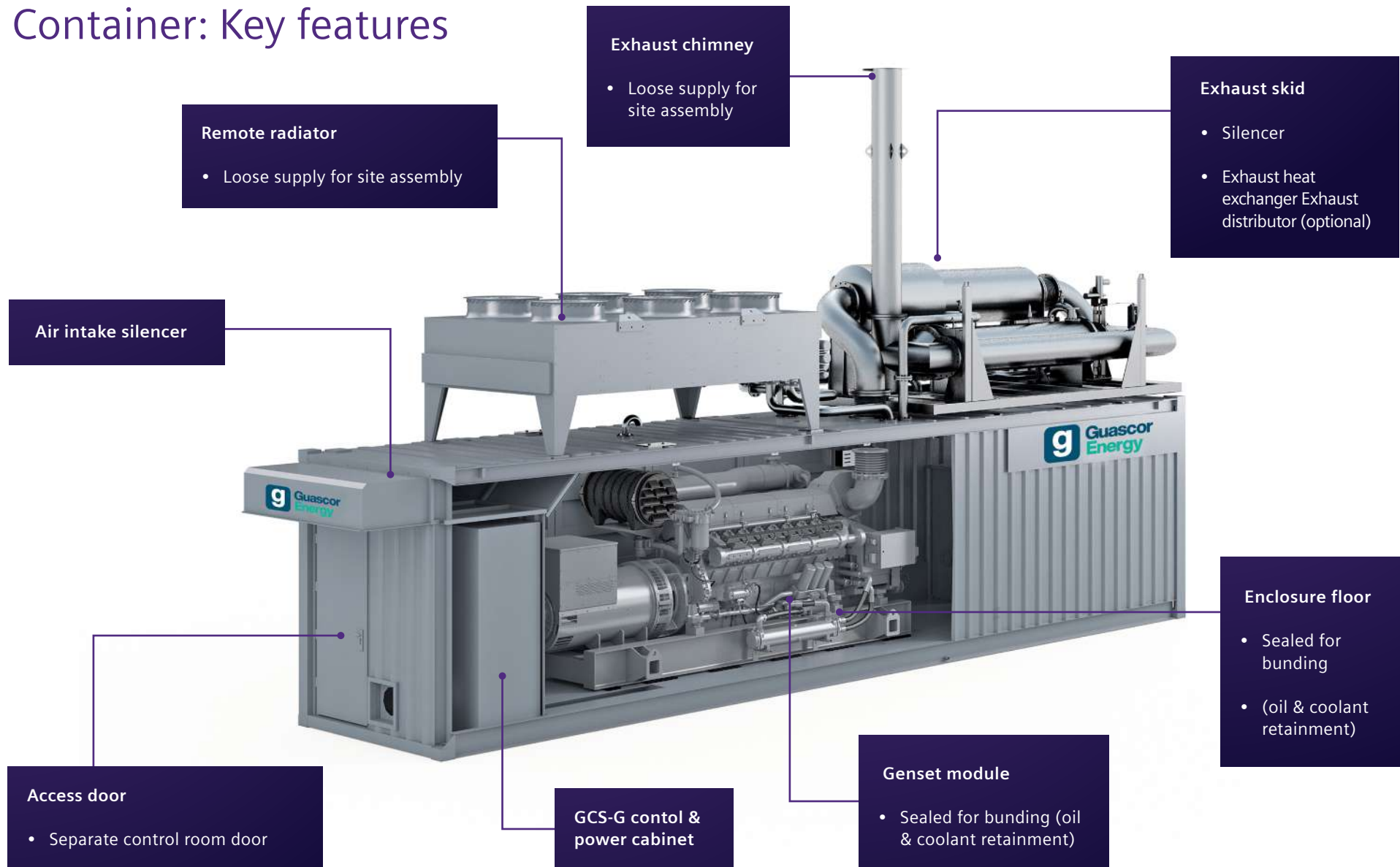

Performance data overview

| Engine Model | Speed (rpm) | Fuel type | Electrical Power (kW) | Electrical Eff. (%) | Thermal Power (kW) | Thermal Eff. (%) | Global Eff. (%) | Engine Dimensions [L x W x H] (m) | Engine Dry Weight (kg) | Genset Dimensions [L x W x H] (m) | Genset Dry Weight [kg] |
|--------------|-------------|-------------|-----------------------|---------------------|--------------------|------------------|-----------------|-----------------------------------|------------------------|-----------------------------------|------------------------|
| SGE-18SL | 1,200 | Natural gas | 241 | 38.6 | 320 | 51.3 | 89.9 | 2.0 x 0.95 x 1.46 | 2,700 | 3.02 x 1.2 x 1.85 | 4,000 |
| SGE-24SL | | Natural gas | 322 | 36.1 | 485 | 54.6 | 90.7 | 2.61 x 0.95 x 1.46 | 3,500 | 3.66 x 1.27 x 1.91 | 4,940 |
| SGE-36SL | | Natural gas | 484 | 38.6 | 656 | 52.2 | 90.8 | 2.64 x 1.37 x 1.74 | 4,200 | 3.83 x 1.66 x 2.13 | 7,230 |
| SGE-48SL | | Natural gas | 648 | 37.7 | 980 | 55.1 | 92.8 | 3.14 x 1.37 x 1.74 | 5,450 | 4.4 x 1.66 x 2.18 | 9,225 |
| SGE-56SL | | Natural gas | 762 | 39.0 | 1,013 | 51.8 | 90.8 | 3.0 x 1.55 x 2.2 | 5,800 | 4.67 x 1.66 x 2.18 | 10,000 |
| SGE-18SL | 1,500 | Natural gas | 303 | 39.1 | 396 | 51.0 | 90.1 | 2.0 x 0.95 x 1.46 | 2,700 | 3.02 x 1.2 x 1.85 | 4,000 |
| SGE-24SL | | Natural gas | 404 | 38.5 | 546 | 51.9 | 90.4 | 2.61 x 0.95 x 1.46 | 3,500 | 3.66 x 1.27 x 1.91 | 4,940 |
| SGE-36SL | | Natural gas | 610 | 38.9 | 810 | 51.7 | 90.6 | 2.64 x 1.37 x 1.74 | 4,200 | 3.83 x 1.66 x 2.13 | 7,230 |
| SGE-48SL | | Natural gas | 811 | 38.8 | 1,093 | 52.2 | 91.0 | 3.14 x 1.37 x 1.74 | 5,450 | 4.4 x 1.66 x 2.18 | 9,225 |
| SGE-56SL | | Natural gas | 954 | 39.0 | 1,280 | 52.2 | 91.2 | 3.0 x 1.55 x 2.2 | 5,800 | 4.67 x 1.66 x 2.18 | 10,000 |
| SGE-56SL T30 | | Natural gas | 1,058 | 39.8 | 1,379 | 51.8 | 91.6 | 3.0 x 1.55 x 2.2 | 5,800 | 4.67 x 1.66 x 2.18 | 10,000 |
| SGE-18SL | 1,800 | Natural gas | 336 | 37.4 | 477 | 53.0 | 90.4 | 2.0 x 0.95 x 1.46 | 2,700 | 3.02 x 1.2 x 1.85 | 4,000 |
| SGE-24SL | | Natural gas | 436 | 38.5 | 666 | 55.1 | 93.6 | 2.61 x 0.95 x 1.46 | 3,500 | 3.66 x 1.27 x 1.91 | 4,940 |
| SGE-36SL | | Natural gas | 676 | 37.7 | 953 | 53.1 | 90.8 | 2.64 x 1.37 x 1.74 | 4,200 | 3.83 x 1.66 x 2.13 | 7,230 |
| SGE-48SL | | Natural gas | 874 | 36.1 | 1,340 | 55.4 | 91.5 | 3.14 x 1.37 x 1.74 | 5,450 | 4.4 x 1.66 x 2.18 | 9,225 |
| SGE-56SL | | Natural gas | 1,030 | 39.0 | 1,534 | 54.5 | 93.5 | 3.0 x 1.55 x 2.2 | 5,800 | 4.67 x 1.66 x 2.18 | 10,000 |

We power the world with innovative gas engines

| Engine Model | Speed (rpm) | Fuel type | Electrical Power (kW) | Electrical Eff. (%) | Thermal Power (kW) | Thermal Eff. (%) | Global Eff. (%) | Engine Dimensions [L x W x H] (m) | Engine Dry Weight (kg) | Genset Dimensions [L x W x H] (m) | Genset Dry Weight [kg] |
|--------------|-------------|-----------|-----------------------|---------------------|--------------------|------------------|-----------------|-----------------------------------|------------------------|-----------------------------------|------------------------|
| SGE-18SL | 1,200 | Biogas | 241 | 38.4 | 322 | 51.4 | 89.8 | 2.0 x 0.95 x 1.46 | 2,700 | 3.02 x 1.2 x 1.85 | 4,000 |
| SGE-24SL | | Biogas | 322 | 36.0 | 486 | 54.5 | 90.5 | 2.61 x 0.95 x 1.46 | 3,500 | 3.66 x 1.27 x 1.91 | 4,940 |
| SGE-36SL | | Biogas | 484 | 38.3 | 663 | 52.4 | 90.7 | 2.64 x 1.37 x 1.74 | 4,200 | 3.83 x 1.66 x 2.13 | 7,230 |
| SGE-48SL | | Biogas | 648 | 36.3 | 982 | 55.0 | 91.3 | 3.14 x 1.37 x 1.74 | 5,450 | 4.4 x 1.66 x 2.18 | 9,225 |
| SGE-56SL | | Biogas | 762 | 38.6 | 1,026 | 52.0 | 90.6 | 3.0 x 1.55 x 2.2 | 5,800 | 4.67 x 1.66 x 2.18 | 10,000 |
| SGE-18SL | 1,500 | Biogas | 303 | 39.0 | 398 | 51.0 | 90.0 | 2.0 x 0.95 x 1.46 | 2,700 | 3.02 x 1.2 x 1.85 | 4,000 |
| SGE-24SL | | Biogas | 404 | 38.4 | 546 | 51.8 | 90.2 | 2.61 x 0.95 x 1.46 | 3,500 | 3.66 x 1.27 x 1.91 | 4,940 |
| SGE-36SL | | Biogas | 610 | 38.9 | 810 | 51.6 | 90.5 | 2.64 x 1.37 x 1.74 | 4,200 | 3.83 x 1.66 x 2.13 | 7,230 |
| SGE-48SL | | Biogas | 811 | 38.7 | 1,097 | 52.2 | 90.9 | 3.14 x 1.37 x 1.74 | 5,450 | 4.4 x 1.66 x 2.18 | 9,225 |
| SGE-56SL | | Biogas | 954 | 38.9 | 1,287 | 52.2 | 91.1 | 3.0 x 1.55 x 2.2 | 5,800 | 4.67 x 1.66 x 2.18 | 10,000 |
| SGE-18SL | 1,800 | Biogas | 336 | 37.2 | 480 | 53.1 | 90.3 | 2.0 x 0.95 x 1.46 | 2,700 | 3.02 x 1.2 x 1.85 | 4,000 |
| SGE-24SL | | Biogas | 436 | 35.9 | 663 | 54.7 | 90.6 | 2.61 x 0.95 x 1.46 | 3,500 | 3.66 x 1.27 x 1.91 | 4,940 |
| SGE-36SL | | Biogas | 676 | 37.6 | 955 | 53.1 | 90.7 | 2.64 x 1.37 x 1.74 | 4,200 | 3.83 x 1.66 x 2.13 | 7,230 |
| SGE-48SL | | Biogas | 874 | 36.0 | 1,345 | 55.4 | 91.4 | 3.14 x 1.37 x 1.74 | 5,450 | 4.4 x 1.66 x 2.18 | 9,225 |
| SGE-56SL | | Biogas | 1,030 | 36.4 | 1,540 | 54.6 | 91.0 | 3.0 x 1.55 x 2.2 | 5,800 | 4.67 x 1.66 x 2.18 | 10,000 |

Performance data overview

| Engine Model | Speed (rpm) | Fuel type | Electrical Power (kW) | Electrical Eff. (%) | Thermal Power (kW) | Thermal Eff. (%) | Global Eff. (%) | Engine Dimensions [L x W x H] (m) | Engine Dry Weight (kg) | Genset Dimensions [L x W x H] (m) | Genset Dry Weight [kg] |
|--------------|-------------|-------------|-----------------------|---------------------|--------------------|------------------|-----------------|-----------------------------------|------------------------|-----------------------------------|------------------------|
| SGE-56SM | 1,500 | Natural gas | 1,025 | 39.7 | 1,319 | 51.0 | 90.7 | 3.0 x 1.55 x 2.2 | 5,800 | 4.67 x 1.66 x 2.18 | 10,000 |
| | 1,800 | Natural gas | 1,063 | 37.9 | 1,486 | 52.9 | 90.8 | | | | |
| | 1,500 | Biogas | 1,025 | 39.4 | 1,330 | 51.1 | 90.5 | | | | |
| | 1,800 | Biogas | 1,063 | 37.8 | 1,494 | 52.9 | 90.7 | | | | |
| SGE-18SR | | Natural gas | 268 | 32.4 | 498 | 60.1 | 92.5 | 2.55 x 1.19 x 2.30 | 2,750 | 2.67 x 1.36 x 2.43 | 4,100 |
| SGE-24SR | | Natural gas | 361 | 31.6 | 698 | 61.2 | 92.8 | 2.99 x 1.23 x 2.58 | 3,500 | 3.00 x 1.38 x 2.79 | 5,200 |
| SGE-36SR | 1,800 | Natural gas | 539 | 32.5 | 1,000 | 60.3 | 92.8 | 2.91 x 1.61 x 3.35 | 4,500 | 3.18 x 1.75 x 3.50 | 7,750 |
| SGE-48SR | | Natural gas | 724 | 31.8 | 1,403 | 61.5 | 93.3 | 3.42 x 1.61 x 3.75 | 5,400 | 4.26 x 1.75 x 3.91 | 9,250 |
| SGE-56SR | | Natural gas | 839 | 33.2 | 1,518 | 60.1 | 93.3 | 3.42 x 1.52 x 4.03 | 5,600 | 4.26 x 1.75 x 3.91 | 9,300 |
| SGE-56HM | 1,200 | Natural gas | 1,011 | 42.5 | 1,120 | 47.1 | 89.6 | 4.04 x 2.14 x 2.22 | 7,500 | 5.54 x 2.14 x 2.32 | 12,200 |
| SGE-24HM | | Natural gas | 501 | 42.7 | 564 | 48.0 | 90.7 | 3.22 x 2.08 x 1.59 | 4,200 | 3.95 x 2.08 x 1.74 | 6,230 |
| SGE-42HM | 1,500 | Natural gas | 1,011 | 43.0 | 1,090 | 46.4 | 89.4 | 3.57 x 2.15 x 2.37 | 6,250 | 4.86 x 2.15 x 2.37 | 10,735 |
| SGE-56HM | | Natural gas | 1,315 | 43.4 | 1,400 | 46.2 | 89.6 | 4.04 x 2.14 x 2.22 | 7,500 | 5.54 x 2.14 x 2.32 | 12,200 |
| SGE-24HM | | Natural gas | 499 | 40.5 | 599 | 48.5 | 89.0 | 3.22 x 2.08 x 1.59 | 4,200 | 3.95 x 2.08 x 1.74 | 6,230 |
| SGE-42HM | 1,800 | Natural gas | 1,007 | 41.1 | 1,184 | 48.4 | 89.5 | 3.57 x 2.15 x 2.37 | 6,250 | 4.86 x 2.15 x 2.37 | 10,735 |
| SGE-56HM | | Natural gas | 1,305 | 41.3 | 1,534 | 48.4 | 89.7 | 4.04 x 2.14 x 2.22 | 7,500 | 5.54 x 2.14 x 2.32 | 12,200 |

We power the world with innovative gas engines

| Engine Model | Speed (rpm) | Fuel type | Electrical Power (kW) | Electrical Eff. (%) | Thermal Power (kW) | Thermal Eff. (%) | Global Eff. (%) | Engine Dimensions [L x W x H] (m) | Engine Dry Weight (kg) | Genset Dimensions [L x W x H] (m) | Genset Dry Weight [kg] |
|--------------|-------------|-------------|-----------------------|---------------------|--------------------|------------------|-----------------|-----------------------------------|------------------------|-----------------------------------|------------------------|
| SGE - 56HM | 1,200 | Biogas | 1,011 | 42.2 | 1132 | 47,3 | 89.5 | 4.04 x 2.14 x 2.22 | 7,500 | 5.54 x 2.14 x 2.32 | 12,200 |
| SGE-24HM | | Biogas | 501 | 42.5 | 567 | 48.1 | 90.6 | 3.22 x 2.08 x 1.59 | 4,200 | 3.95 x 2.08 x 1.74 | 6,230 |
| SGE-42HM | 1500 | Biogas | 1,011 | 42.8 | 1,101 | 46.6 | 89.4 | 3.57 x 2.15 x 2.37 | 6,250 | 4.86 x 2.15 x 2.37 | 10,735 |
| SGE-56HM | | Biogas | 1,315 | 43.1 | 1,412 | 46.3 | 89.4 | 4.04 x 2.14 x 2.22 | 7,500 | 5.54 x 2.14 x 2.32 | 12,200 |
| SGE-24HM | | Biogas | 499 | 40.2 | 604 | 48.6 | 88.8 | 3.22 x 2.08 x 1.59 | 4,200 | 3.95 x 2.08 x 1.74 | 6,230 |
| SGE-42HM | 1,800 | Biogas | 1,007 | 41.0 | 1,190 | 48.5 | 89.5 | 3.57 x 2.15 x 2.37 | 6,250 | 4.86 x 2.15 x 2.37 | 10,735 |
| SGE-56HM | | Biogas | 1,305 | 41.1 | 1,547 | 48.6 | 89.7 | 4.04 x 2.14 x 2.22 | 7,500 | 5.54 x 2.14 x 2.32 | 12,200 |
| SGE-86EM | 1,500 | Natural gas | 2,013 | 45.5 | 2,085 | 47.1 | 92.6 | 6.56 x 2.43 x 2.75 | 15,500 | 6.56 x 2.43 x 2.75 | 25,000 |
| SGE-100EM | 1,200 | Natural gas | 2,007 | 45.3 | 2,057 | 46.5 | 91.8 | 6.56 x 2.43 x 2.75 | 15,500 | 6.56 x 2.43 x 2.75 | 25,000 |

Notes

- (1) For S Series: Natural Gas MN>75 and Biogas: 62,5% CH₄, 36% CO₂ and 1,5% N₂. For other type of gases, please contact Engines.
- (2) For H and E Series: Natural Gas MN>80 and Biogas 67% CH₄ and 33% CO₂ (only for H Series).
- (3) Thermal efficiency of the S Series engines calculated considering the exhaust gases heat recovery until 120°C.
- (4) Thermal efficiency of the E Series engines calculated considering the exhaust gases heat recovery until 80°C.
- (5) Emissions level for SR Series: 0,1 g/bHPH.
- (6) SR dimensions including catalyzer.

Remarks

- Engine performance data acc. to ISO 3046/1, 25°C and 500 meters above sea level, with a tolerance of +5%.
- Emissions level: NO_x < 500 mg/Nm³ (50 Hz) and 1 g/bHPH (60Hz).
- Lower emission engines are available. Please, contact for performance data.
- Electrical power at power factor = 1.400 V (50Hz) and 480 V(60 Hz).
 - The dimensions and weights are approximate values and are subject to changes without prior notice.
 - The values given in this data sheet are for information purposes only and not binding.



PH 1800 999 922

ADELAIDE

39 Plymouth Road
Wingfield SA 5013

P +61 (0)8 8347 8400
E dtppsalsadelaide@drivetrainpower.com

KALGOORLIE

30 Atbara Street
Kalgoorlie WA 6430

P +61 (0)8 9251 8071
E kalsales@drivetrainpower.com

MACKAY

14 Elvin Street
Paget QLD 4740

P +61 (0)7 4952 3611
E dtppsalsmackay@drivetrainpower.com

MELBOURNE

Unit 1/75, Star Crescent
Hallam VIC 3803

P +61 (0)3 8612 6722
E dtppsalshallam@drivetrainpower.com

MT ISA

10 Ryan Road
MT Isa QLD 4825

P +61 (0)7 4952 3611
E dtppsalsmackay@drivetrainpower.com

NEWCASTLE

13 Firebrick Drive
Thornton NSW 2322

P +61 (0)2 4088 2310
E dtppsalsnewcastle@drivetrainpower.com

PERTH

135 Pilbara Street
Welshpool WA 6106

P +61 (0)8 9251 8067
E dtppsalsperth@drivetrainpower.com

CORPORATE

Level 22, 535 Bourke Street
Melbourne VIC 3000

P +61 (0)3 8620 8900
E Info@drivetrainpower.com